

*The eGaN[®] Technology
Journey Continues*

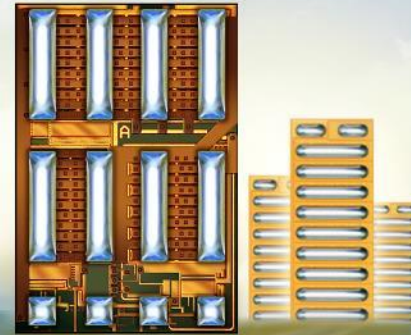

EPC2054 Thermal Model

EPC2054 FEA thermal simulations



- The thermal model applies to EPC2054.
- A power dissipation of 1 W in the device active area is assumed.
- Finite element analysis (FEA) thermal simulations
 - $R_{\Theta JB}$ and $R_{\Theta JC}$ are obtained by stationary simulations.
 - $Z_{\Theta JB}$ and $Z_{\Theta JC}$ are obtained by transient simulations.
- R-C thermal model is generated.

EPC2054 geometry in simulation

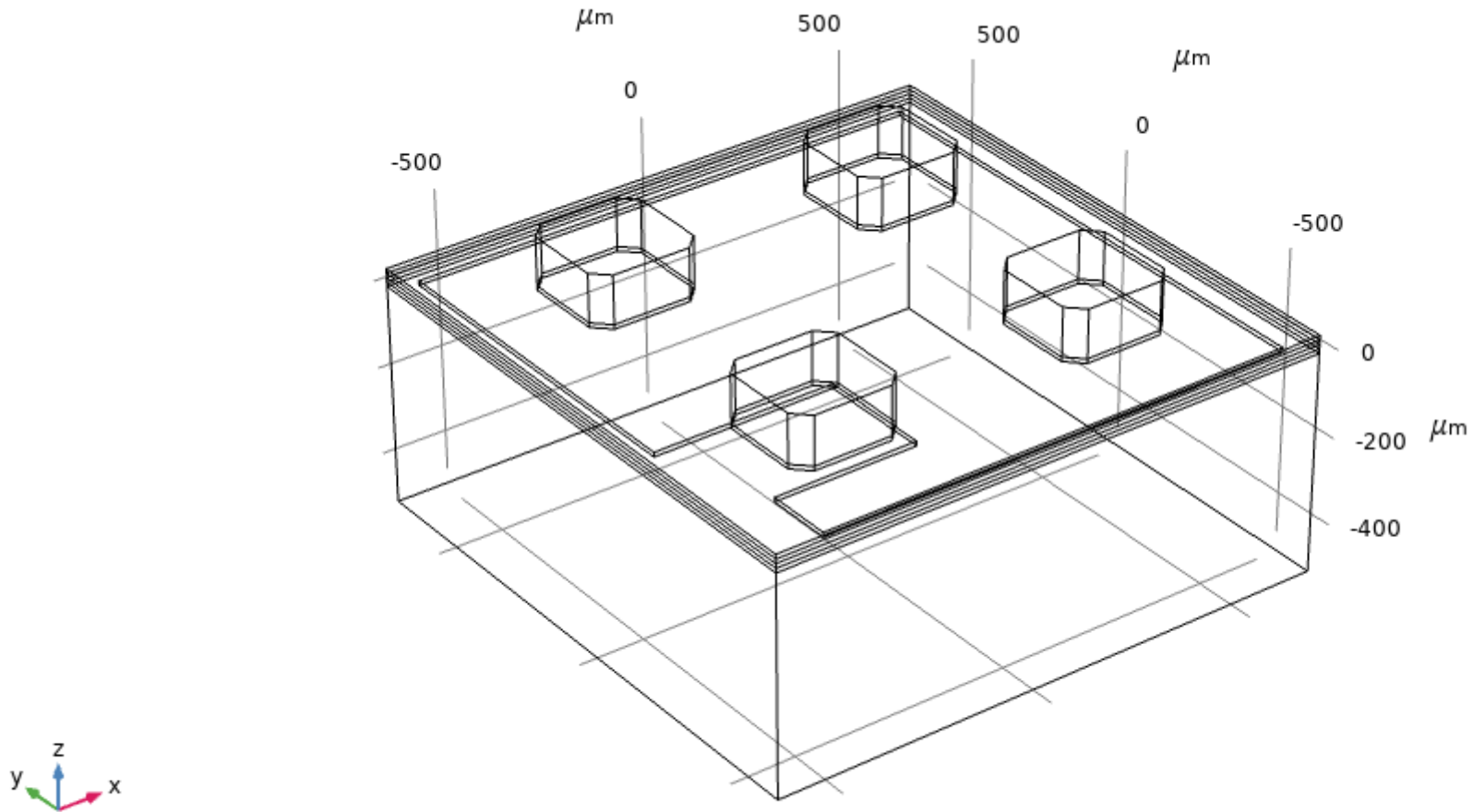

EPC2054 Steady-state $R_{\theta JB}$

Typical $R_{\theta JB} = 14 \text{ }^\circ\text{C/W}$

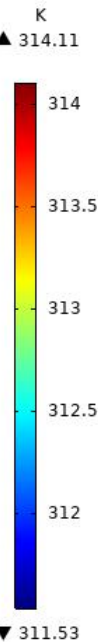
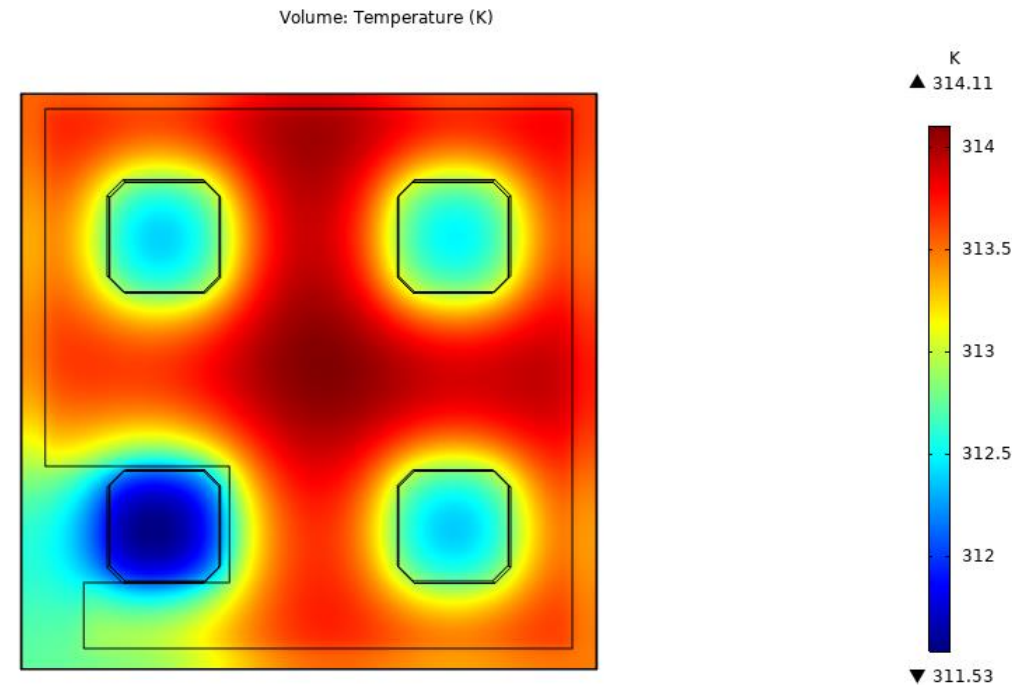
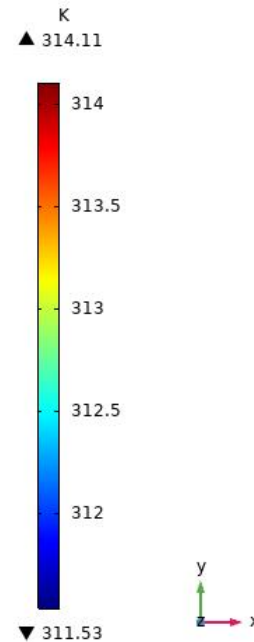
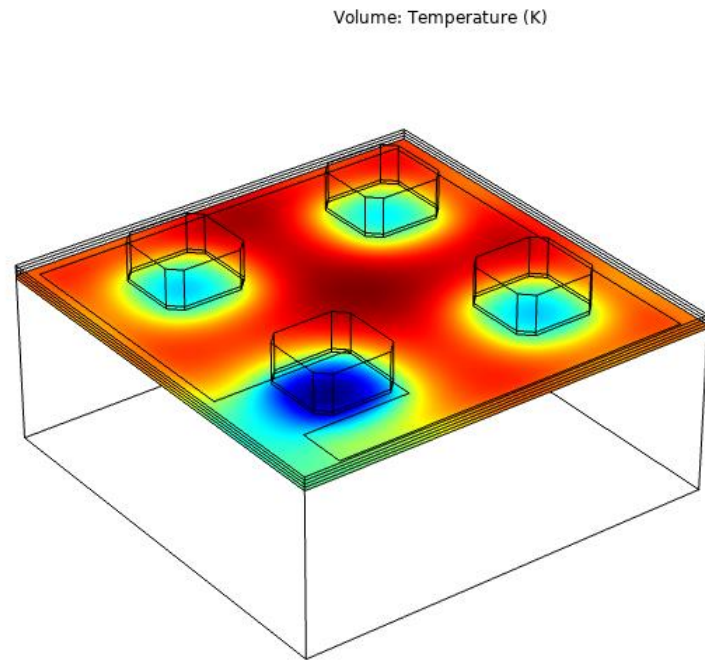

- Operating condition: Power = 1 W in the active area.
- Boundary condition: Temperature of top of solder bumps set to be 300 K.

EPC2054 Steady-state $R_{\theta JC}$

Typical $R_{\theta JC} = 2.3 \text{ }^{\circ}\text{C/W}$

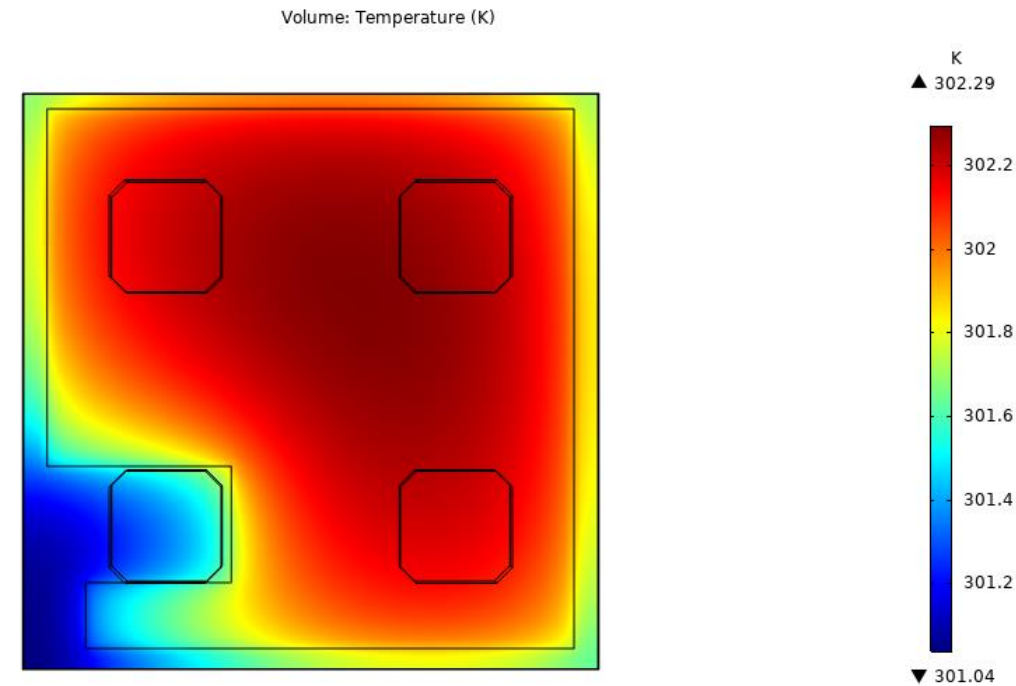
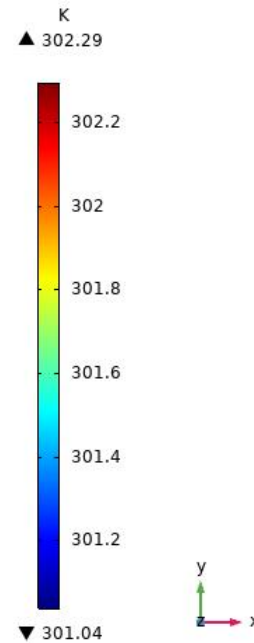
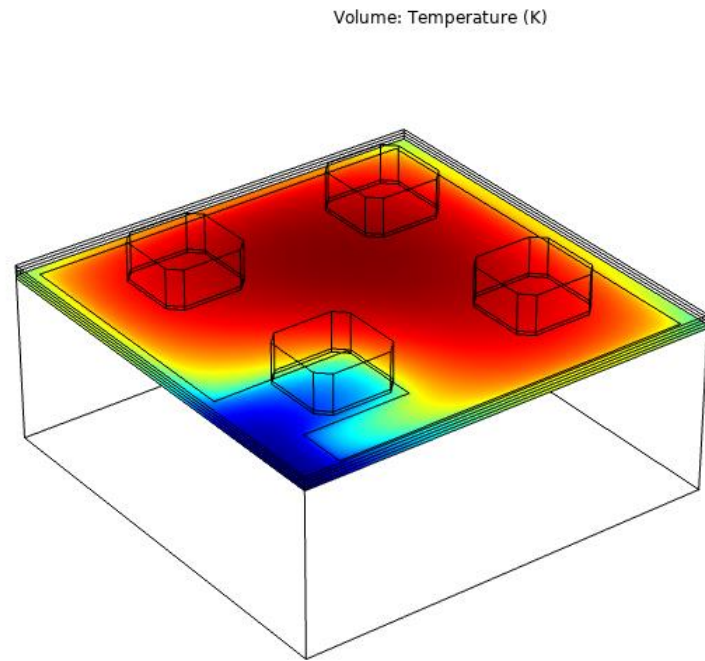

- Operating condition: Power = 1 W in the active area.
- Boundary condition: Temperature of the device backside set to be 300 K.

EPC2054 $Z_{\Theta JB}$ R-C thermal model

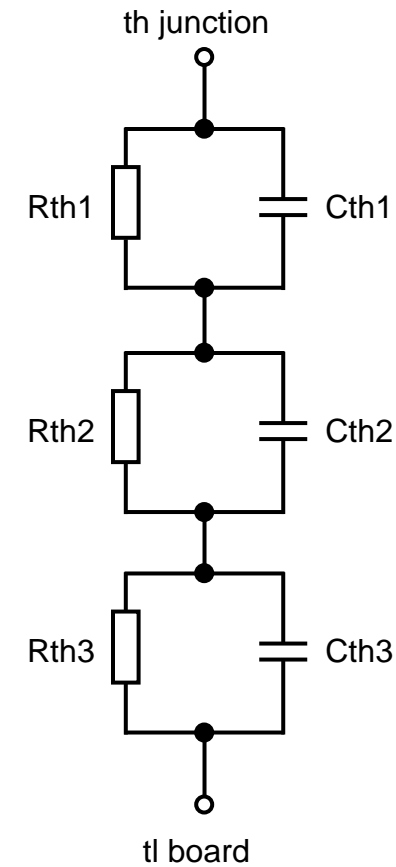
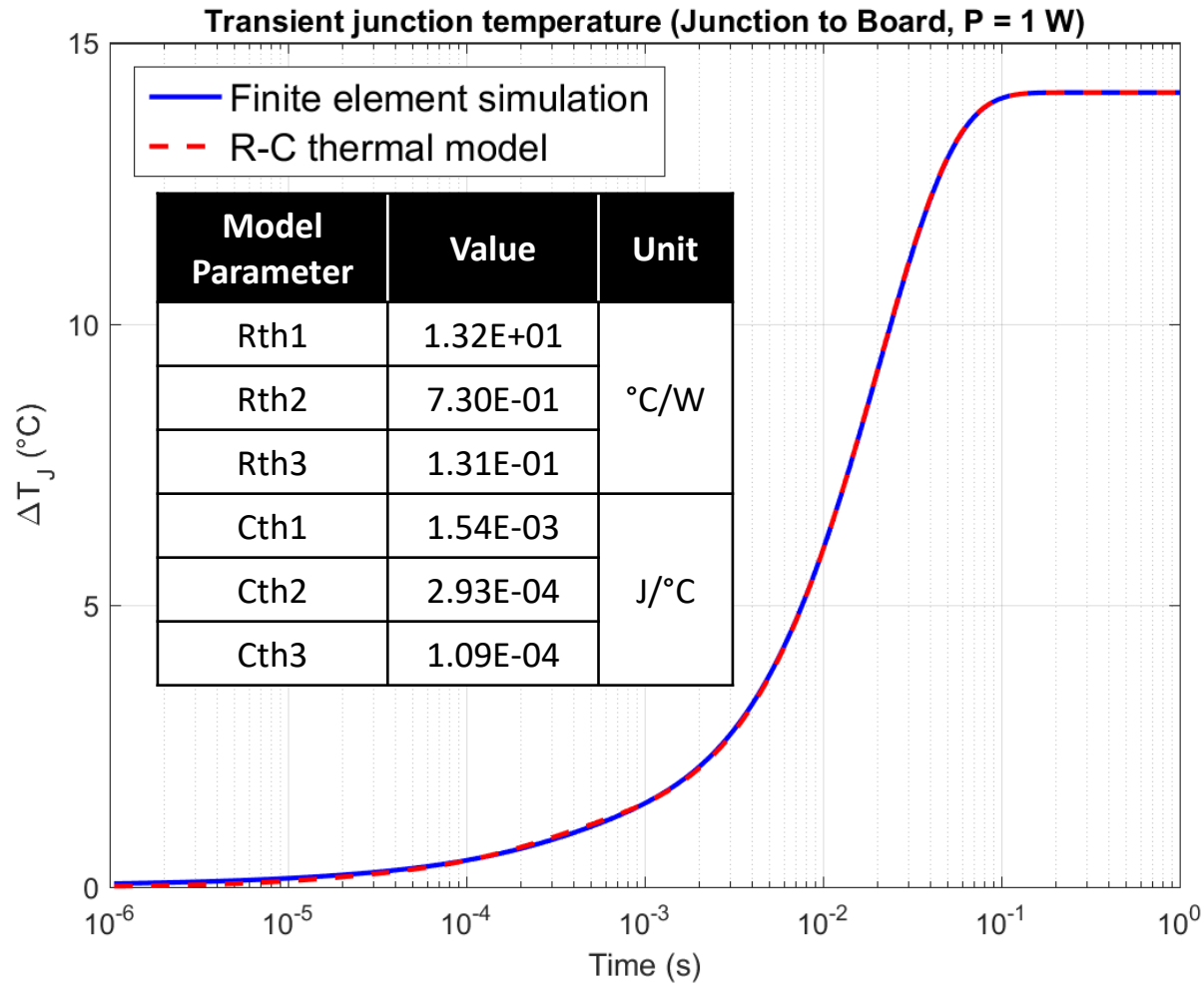

EPC2054 $Z_{\Theta JC}$ R-C thermal model

